

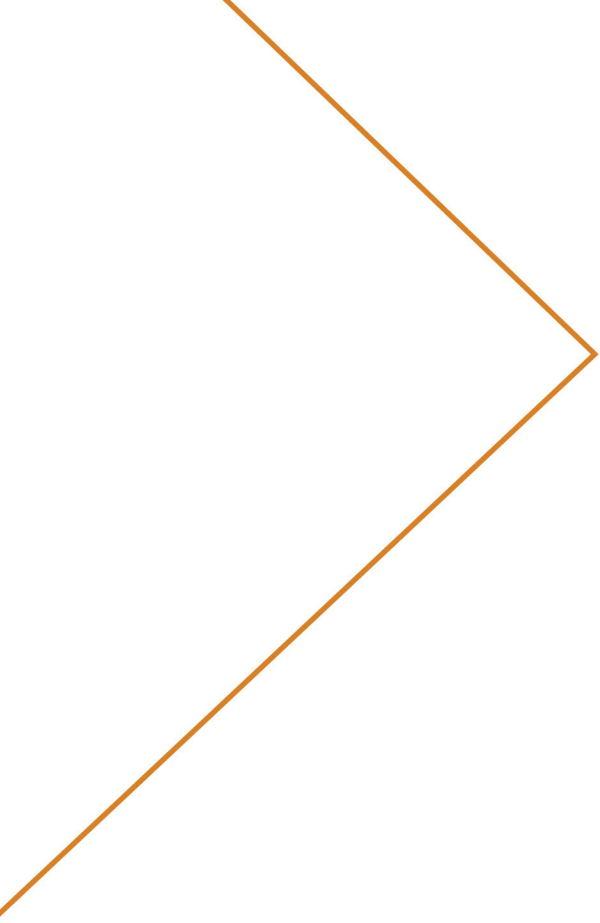

ADVANCED ERGONOMIC SOLUTIONS

MADE
IN 
ITALY

**ERGONOMIC
WORKSTATION
SOLUTIONS**



Zero G torque reaction arms

Zero G

The new ZeroG carbon fiber arm (zero gravity) is the result of an innovative design for maximum performance.

All features related to maneuverability, reaction efficiency and safety has been enhanced to the highest level.

Maximum load capacity allows you to handle heavy tools.



Technical features

- Pneumatic balancing
- Radius: max 2500mm
- Weight range: max 70Kgs
- Max torque: 500Nm
- Handling effort: below 39N
- Floor and ceiling installation



Range and size

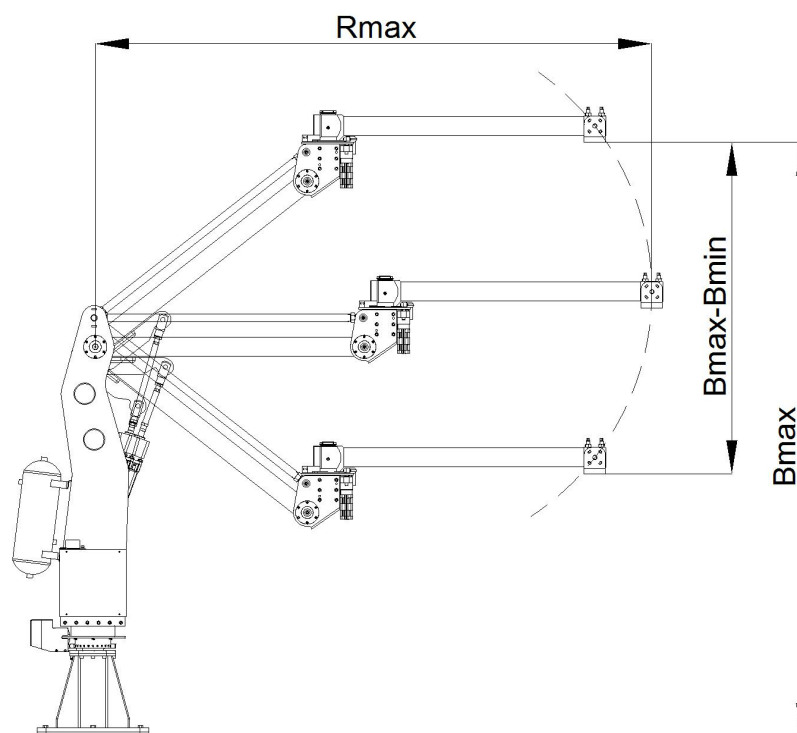

Floor installation range

| Model | Part number | Max torque (Nm) | B max (mm) | Bmax-Bmin (mm) | R max (mm) | Weight range (Kg) | Weight (Kg) |
|----------------|--------------|--------------------|---------------|-------------------|---------------|----------------------|----------------|
| ZeroG 250-1500 | 050.0001.000 | 250 | 2240 | 870 | 1500 | 55 | 215 |
| ZeroG 250-2000 | 050.0002.000 | 250 | 2400 | 1185 | 2000 | 45 | 225 |
| ZeroG 250-2500 | 050.0003.000 | 250 | 2555 | 1490 | 2500 | 35 | 235 |
| ZeroG 500-1500 | 050.0201.000 | 500 | 2390 | 870 | 1500 | 70 | 255 |
| ZeroG 500-2000 | 050.0202.000 | 500 | 2545 | 1185 | 2000 | 60 | 265 |
| ZeroG 500-2500 | 050.0203.000 | 500 | 2700 | 1490 | 2500 | 50 | 275 |

Ceiling installation range

| Model | Part number | Max torque (Nm) | B max (mm) | Bmax-Bmin (mm) | R max (mm) | Weight range (Kg) | Weight (Kg) |
|------------------|--------------|--------------------|---------------|-------------------|---------------|----------------------|----------------|
| ZeroG-S 250-1500 | 050.0051.000 | 250 | 2220 | 870 | 1500 | 55 | 195 |
| ZeroG-S 250-2000 | 050.0052.000 | 250 | 2380 | 1185 | 2000 | 45 | 205 |
| ZeroG-S 250-2500 | 050.0053.000 | 250 | 2535 | 1490 | 2500 | 35 | 215 |
| ZeroG-S 500-1500 | 050.0251.000 | 500 | 2370 | 870 | 1500 | 70 | 240 |
| ZeroG-S 500-2000 | 050.0252.000 | 500 | 2525 | 1185 | 2000 | 60 | 230 |
| ZeroG-S 500-2500 | 050.0253.000 | 500 | 2680 | 1490 | 2500 | 50 | 250 |

Accessories

ZeroG encoder kit

Use

Detection axis X-Y by Posix device

Technical features

The kit includes the provision of 3 incremental encoders and related cables and brackets for connection to the Posix device. Can be integrated with tool custom droppers.



Range

| Model | Part number |
|-------------------|--------------|
| ZeroG Encoder Kit | 055.0302.000 |

Base extensions

Use

The base extension allows adjustment of the torque arm ZeroG height

Technical features

Steel construction

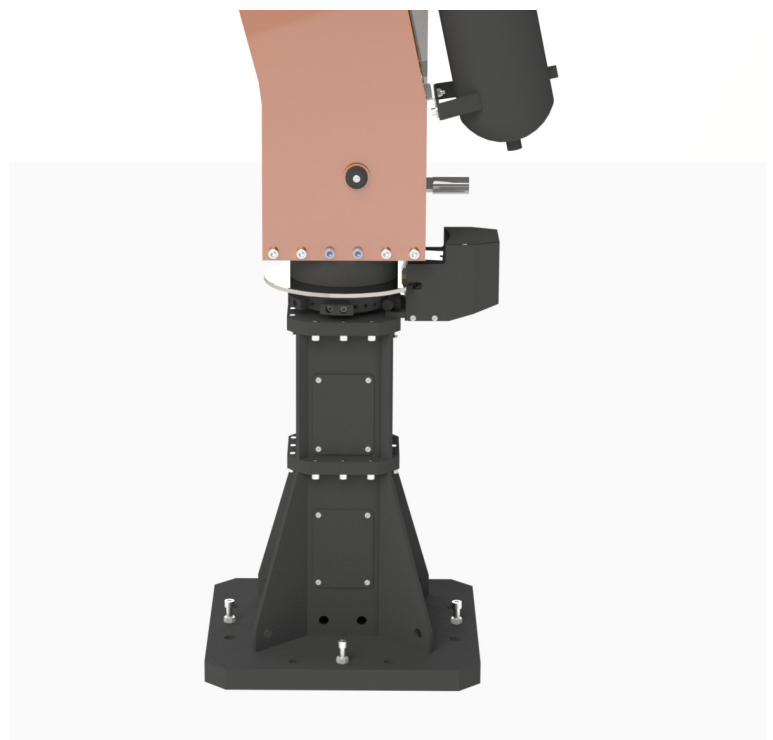

Range

| Model | Part number |
|----------------------|--------------|
| Base extension L250 | 055.0004.000 |
| Base extension L500 | 055.0005.000 |
| Base extension L1000 | 055.0006.000 |

Tool-holder droppers

Use

The tool-holder dropper allows a correct positioning of tool and can be integrated with electromagnetic brakes to allow axial rotation.

Custom droppers are available only on demand and are customized on customer needs.

Technical features

Carbon fiber extension with tool-holder interface



Arm application Hints

TYPE 7 LAYOUT - FLOOR MOUNT
ZERO GRAVITY TORQUE ARM

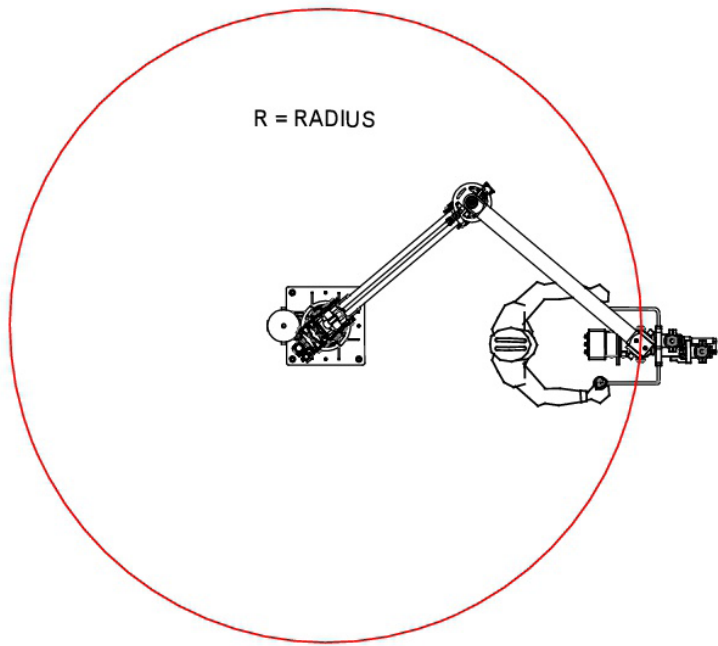
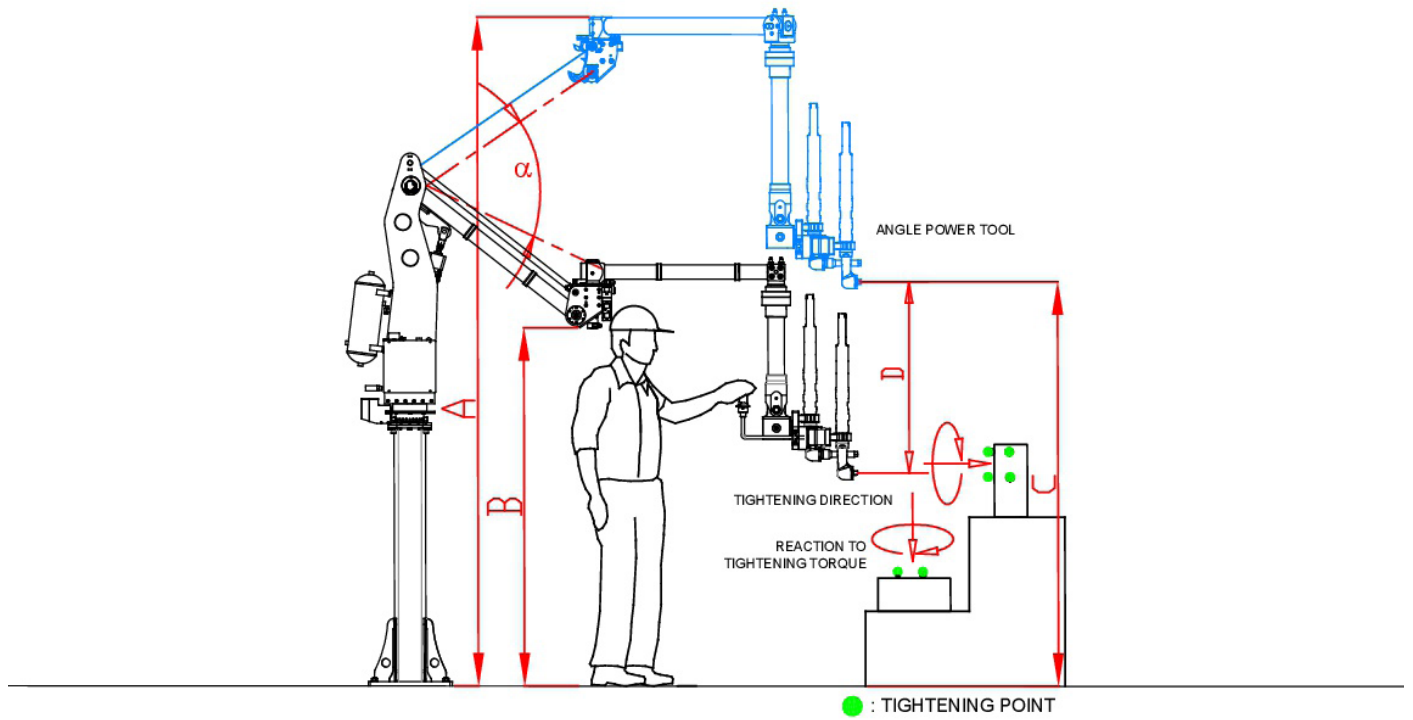

Arm application Hints

TYPE 7 LAYOUT - CEILING MOUNT
ZERO GRAVITY TORQUE ARM

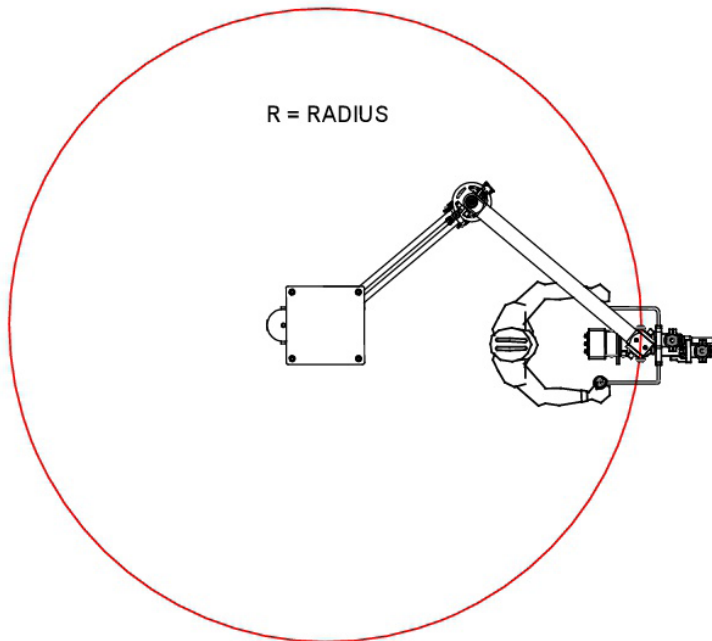
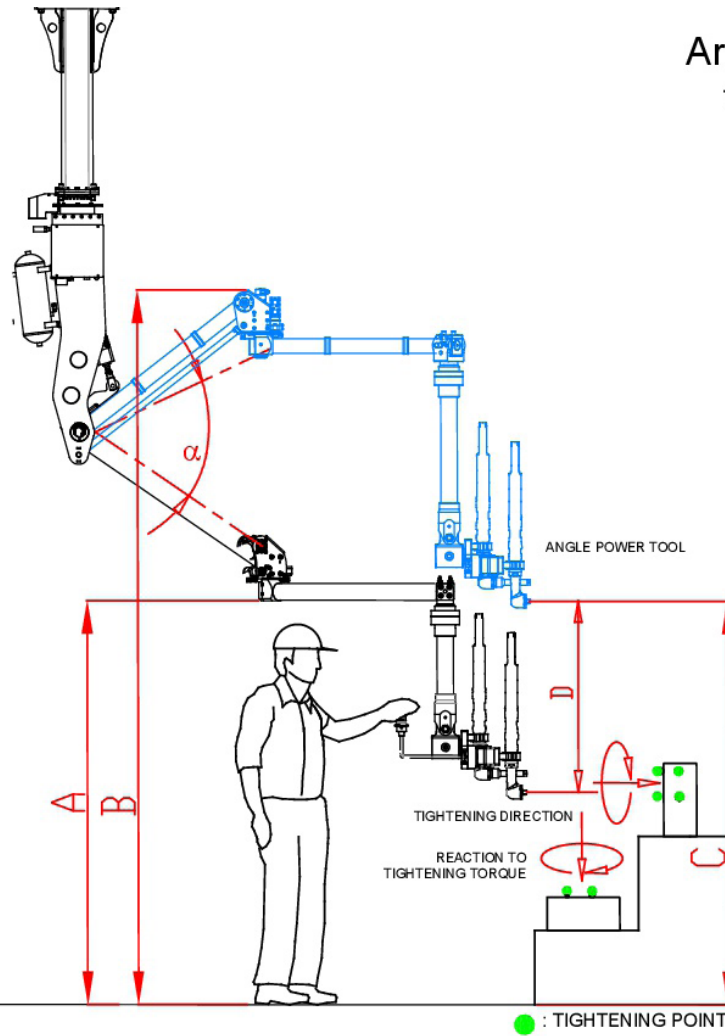

REMARKS: product characteristics maybe changed by BNP without notice in advance

BNP 2018 CATALOGUE

REV.n.0

Approved by the Company's Board of Directors

APPROVED: GM - Carlo Pettenon

DISTRIBUTED BY:



BNP s.r.l.

Viale dell'Artigianato, 9 - 35013 Cittadella (PD) Italia
Tel. +39 049 5974477 Fax. +39 049 5970906

info@bnpsrl.com - www.bnpsrl.com

